

Industrial gas detector, with replaceable cartridge sensor ATEX certified for Zone 1



Video



User's Manual



Certification

The gas detectors in explosion proof housing for use in potentially explosive atmospheres are certificated **CESI 03 ATEX 323 X** (EN60079-0 ed EN60079-1) and characterized by the following EX marking (Directive 2014/34/UE):



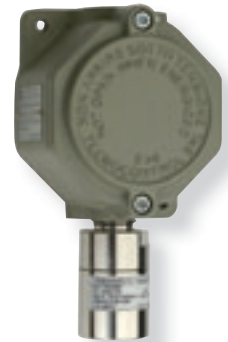



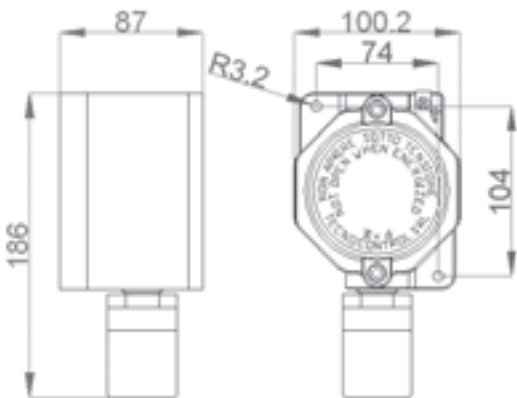





CE 0722  II 2 G Ex d IIC T6 Gb



TS293



- Power supply: 12÷24 Vdc
- Ex marking  : II 2G Ex d IIC T6 Gb
- No. 1 linear 4÷20 mA current output
- Terminals plug-in polarized type

Code	Gas detected	Cartridge replacement	Measuring range	Electrical input	Calibration cylinder	Average time in clean air	Technology
TS293KM	Methane	ZSK01/EX-ZSK02/EX	0÷20% LEL	2 W	B0200	5 years	  
TS293KG	LPG	ZSK01/EX-ZSK02/EX	0÷20% LEL	2 W	B0200	5 years	
TS293KI	Hydrogen	ZSK01/EX-ZSK02/EX	0÷20% LEL	2 W	B0200	5 years	
TS293KB	Petrol	ZSK04/EX	0÷20% LEL	2 W	B0200	5 years	
TS293PM	Methane	ZSP05/EX	0÷100% LEL	2 W	B0200	5 years	  
TS293PG	LPG	ZSP05/EX	0÷100% LEL	2 W	B0200	5 years	
TS293PI	Hydrogen	ZSP05/EX	0÷100% LEL	2 W	B0200	5 years	
TS293PB	Petrol	ZSP05/EX	0÷100% LEL	2 W	B0200	5 years	
TS293PE	Acetylene	ZSP02/EX	0÷100% LEL	2 W	B0200	5 years	
TS293PS	Styrene	ZSP03/EX	0÷100% LEL	2 W	B0200	5 years	
TS293PX	See Table 1	ZSP05/EX	0÷100% LEL	2 W	B0200	5 years	  
TS293PX-H	See Table 2	ZSP02/EX	0÷100% LEL	2 W	B0200	5 years	
TS293EA	Ammonia	ZSEA1/EX	0÷300 ppm	2 W	B0501	5 years	
TS293EA-H	Ammonia	ZSEA2/EX	0÷300 ppm	2 W	B0501	5 years	
TS293EC-S	Carbon monoxide	ZSEC1/EX	0÷300 ppm	2 W	B0210	5 years	
TS293EC-H	Carbon monoxide	ZSEC2/EX	0÷300 ppm	2 W	B0210	5 years	
TS293EH	Hydrogen sulphide	ZSEH1/EX	0÷100 ppm	2 W	B0420	5 years	
TS293EHCN	Hydrochloric acid	ZSEHCN/EX	0÷10 ppm	2 W	B0479	5 years	
TS293EN	Nitrogen monoxide	ZSEN1/EX	0÷300 ppm	2 W	B0472	5 years	
TS293EN2	Nitrogen dioxide	ZSEN2/EX	0÷30 ppm	2 W	on request	5 years	
TS293ES	Sulphur dioxide	ZSES1/EX	0÷20 ppm	2 W	B0468	5 years	  
TS293EO	Oxygen	ZSE01/EX	0÷25% Vol.	2 W	B0416	5 years	